

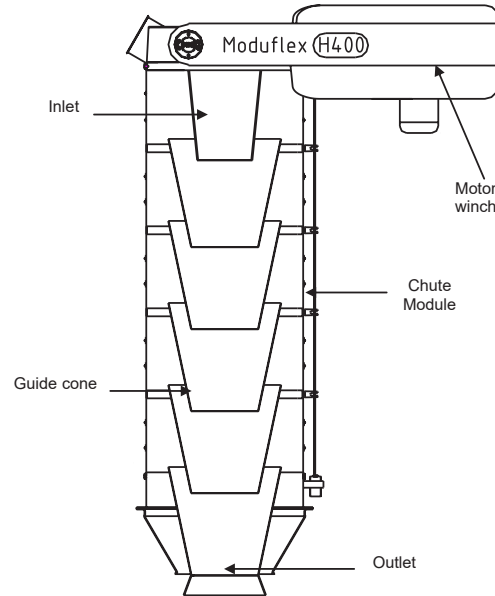

MODUFLEX LOADING CHUTE H400

GENERAL

Brand	Cimbria
Designation	Moduflex Loading Chute
Model	H400
Use	Designed for dust-free out-loading of dry bulk material.



Technical Information - H400

Inlet	Conical Inlet tube in 4 mm steel. Fitting $\varnothing 400$ PN10 flange (DIN 2576B). Mounted with 16 off M24 bolts. Exhaust connection $\varnothing 150$, optionally with automatic closing function.
Chute modules	Type Y - Standard: Yellow. PVC/Polyester. $\varnothing 700\text{mm}/\text{H}=300\text{mm}$. Temperature $-35^{\circ}\text{C} - +70^{\circ}\text{C}$ Type M - Food Grade: Light Grey. PVC/Polyester. $\varnothing 700\text{mm}/\text{H}=300\text{mm}$. Temperature $-30^{\circ}\text{C} - +70^{\circ}\text{C}$ Type W - Special: Misc. PVC/Polyester. $\varnothing 700\text{mm}/\text{H}=300\text{mm}$. Temperature $-35^{\circ}\text{C} - +70^{\circ}\text{C}$ Type B - Heavy Duty: Black. Synthetic rubber. $\varnothing 700\text{mm}/\text{H}=300\text{mm}$. Temperature $-40^{\circ}\text{C} - +130^{\circ}\text{C}$ Type G - ExtremeTemperature: Grey. Teflon/Fiber glass. $\varnothing 700\text{mm}/\text{H}=300\text{mm}$. Temperature $-35^{\circ}\text{C} - +260^{\circ}\text{C}$ Type R - High temperature: Red. Polyester and fiber/silicone rubber. $\varnothing 700/\text{H}=300\text{mm}$. Temp. $-40^{\circ}\text{C} - +150^{\circ}\text{C}$ (peak $+220^{\circ}\text{C}$). Type Z - Low temperature: Green. PVC/PU. $\varnothing 700\text{mm}/\text{H}=300\text{mm}$. Temperature $-60^{\circ}\text{C} - +70^{\circ}\text{C}$ Connection ring in stainless steel Aisi 304, c/w 3 off wire guides in nylon.
Guide cones	Type O - Support ring. Steel, H=30mm Type J - Steel Standard. Steel, H=150mm, pt=2mm. Type L - Steel Overlapping. Steel, H=405mm, pt=2mm.
Outlet	Type T - Tank Outlet with steel cone for loading in tanker truck. Type F - Flat Outlet with dust skirt for loading in open truck. Type M - Multi Outlet with steel cone and dust skirt for loading in tanker truck and open truck.
Motor winch	Motor 0.55-2.2 kW, 1400 rpm. Gear box ratio 100:1. Tight and slack wire indication External 3-point wire hoist system with high precision ball bearings and 3 off winch discs vertically fitted. Hoist wires $\varnothing 5\text{mm}$ available in steel, stainless steel Aisi316 or Long Life steel quality. Self-lubricating wire rollers in Ertalite TX, alternatively steel/stainless steel with bronze bearing
General info	Max. loading capacity approx. $440 \text{ m}^3/\text{hour}$. Recommended connecting value for aspiration $1200 \text{ m}^3/\text{hour}$ 500-1500 Pa. Metal parts available in painted steel st. 37 or stainless steel Aisi 304. Other steel qualities on demand. Surface treatment St. 37: Iron phosphating, 80 micron coating RAL 9010 pure white. Surface treatment Aisi 304: Acid-washed without any further treatment Motor winch covers in ABS - RAL 6005 dark green Available with full approval and certificates for location in ATEX zone 21 and 22 (zone 20 inside the chute)

Accessories for Loading Chute H400, please see separate Data Sheet

MODUFLEX LOADING CHUTE

H400

H400									
	Outlet type TH			Outlet type FH			Outlet type MH		
Cone	Overlapping steel			Overlapping steel			Overlapping steel		
M	L1	L2	L3	L1	L2	L3	L1	L2	L3
1	900	643	257	1286	1029	257			
2	1207	693	514	1593	1079	514			
3	1514	743	771	1900	1129	771			
4	1821	793	1028	2207	1179	1028			
5	2128	843	1285	2514	1229	1285			
6	2435	893	1542	2821	1279	1542	2821	1279	1542
7	2742	943	1799	3128	1329	1799	3128	1329	1799
8	3049	993	2056	3435	1379	2056	3435	1379	2056
9	3356	1043	2313	3742	1429	2313	3742	1429	2313
10	3663	1093	2570	4049	1479	2570	4049	1479	2570
11	3970	1143	2827	4356	1529	2827	4356	1529	2827
12	4277	1193	3084	4663	1579	3084	4663	1579	3084
13	4584	1243	3341	4970	1629	3341	4970	1629	3341
14	4891	1293	3598	5277	1679	3598	5277	1679	3598
15	5198	1343	3855	5584	1729	3855	5584	1729	3855
16	5505	1393	4112	5891	1779	4112	5891	1779	4112
17	5812	1443	4369	6198	1829	4369	6198	1829	4369
18	6119	1493	4626	6505	1879	4626	6505	1879	4626
19	6426	1543	4883	6812	1929	4883	6812	1929	4883
20	6733	1593	5140	7119	1979	5140	7119	1979	5140

H400 with FlexClose - no indicator				
M	LC	L1	L2	L3
2	1149	1459	945	514
3	1456	1766	995	771
4	1763	2073	1045	1028
5	2070	2380	1095	1285
6	2377	2687	1145	1542
7	2684	2994	1195	1799
8	2991	3301	1245	2056
9	3298	3608	1295	2313
10	3605	3915	1345	2570

H400 with Flexfill				
M	LC	L1	L2	L3
3	1737	2056	1488	568
4	2044	2363	1538	825
5	2351	2670	1588	1082
6	2658	2977	1638	1339
7	2965	3284	1688	1596
8	3272	3591	1738	1853
9	3579	3898	1788	2110
10	3886	4205	1838	2367

H400 with FlexClose + indicator					Vibrationrod		
Rotating+ capacitive indicator					L1	L2	L3
M	LC	L1	L2	L3	L1	L2	L3
2	1149	1619	1105	514	1689	1175	514
3	1456	1926	1155	771	1996	1225	771
4	1763	2233	1205	1028	2303	1275	1028
5	2070	2540	1255	1285	2610	1325	1285
6	2377	2847	1305	1542	2917	1375	1542
7	2684	3154	1355	1799	3224	1425	1799
8	2991	3461	1405	2056	3531	1475	2056
9	3298	3768	1455	2313	3838	1525	2313
10	3605	4075	1505	2570	4145	1575	2570

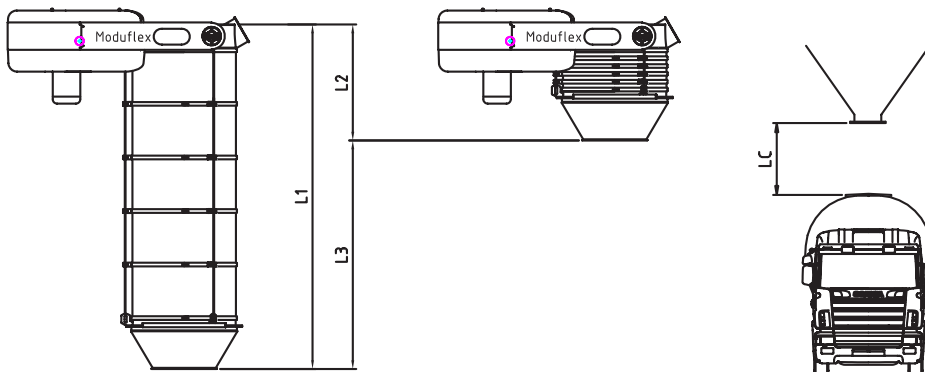

LC measure to be used when the loading chute is fitted with FlexClose or FlexFill.